

# designcase

## T2 Temporary / Demountable Gallery and Museum Wall System

### Product Information and Overview



T2 Walls for HOTA, Gold Coast. Lyrical Landscapes Exhibition.  
Image courtesy of HOTA – Home of the Arts

Document Revision Date / Number: July 2022-1

Dear Friend of Designcase,

I welcome the opportunity to introduce the Designcase T2 Gallery and Museum Temporary / Demountable Wall System. T2 is a new product, designed and developed by Designcase, to complement our existing range of Gallery and Museum Products. After an extensive engineering and prototype development phase, we are now running bulk extrusion and supplying the T2 product to market.

The T2 Wall System has been developed in our Canberra workshop, and is the culmination of our combined experience with existing proprietary wall systems, and as a response to numerous requests to develop a heavy-duty, large format, modular Gallery Wall System that can be project specific manufactured in Australia. In addition to the wall modules, we have a comprehensive suite of materials handling equipment, storage and transport stillages, ballast and fixing options, all designed to make deploying and using T2 as easy and safe as possible.

If you have any queries regarding the Designcase T2 Gallery walls, our any of our Proprietary Showcases, or our Museum lighting options from LjusDesign, please do not hesitate to contact me.

I sincerely look forwards to working with you on a project in the near future.

Phillip Quartly  
Manager Museum Projects  
M: 0423 023 735



T2 Walls for HOTA, Gold Coast. Lyrical Landscapes Exhibition.  
Image courtesy of HOTA – Home of the Arts

T2 has the following build specifications and product features:

- Heavy duty internal aluminium bolt-together frame structure, with (joinery) Face Panels all round. Vertical End Modules (fixed frames) are linked to each other with a series of Horizontal Cross Rails. Internal framing is CNC machined and assembly is simply bolt-on Horizontal Cross Rails to End Modules. Face Panels are split-baton hung, to a standard CNC pocketed set-out.
- Standard walls are based on a 1200, 2400 or 3600mm wide 'Module'. T2 is designed to accommodate special sizes unique to a specific project, with little or no cost implication for customisations; all Modules are made to order and use standard extrusion and components regardless of overall footprint and height. A minimum wall depth of 600mm is required to allow operators to move inside the wall cavity when sheeted. Higher wall modules will usually require a deeper footprint and ballast or fixing points, as noted in an engineer's recommendation and guideline.
- Face Panels can be made from a variety of materials, but are usually supplied as 16mm E0MDF. Alternative Face panel materials are available as a special order, such as Lightweight 18mm Ply (half the weight of MDF, ideal for higher walls or higher frequency changeover use). The location of face panels-to-cross rails relies upon pocketed CNC set-outs; as such replacement face panels can be ordered and supplied with split-batons pre-fitted, ready to hang.
  - The Face Panel is intended to be a disposable commodity, replaced as or when required. Patching of smaller holes (art hanging for example) is common without reducing the integrity of the panel. Larger penetrations (such as AV screens, showcases, etc.) would usually require a replacement face panel at exhibitions end.
  - Face Panels do not need to be returned to the manufacturer or on-seller for re-facing or patching; unlike other products on the market there are no on-going legacy costs associated to Face Panels.
- Internal aluminium frames can be fully flat-packed for storage and freight. A suite of wall structures will have identical components and therefore all elements are interchangeable on identical walls. Designcase can supply a variety of storage options, vertical racks and crates which reduce manual handling and improve storage efficiency.
- Assembled aluminium wall frames can be relocated by use of forklift / electric pallet stackers or pallet-jacks and (depending on the height-to-depth ratio) 'Scoot' dollies. No physical lifting of assembled wall modules is required. Wall modules cannot be relocated with face panels attached or ballast deployed; there is too much associated weight. 2 operators minimum (with the correct materials handling equipment) are required to relocate wall modules. Relocation and re-configuration can be undertaken by trained Gallery staff; Designcase do not need to be present during demount, build or reconfiguration. DC would welcome the opportunity to quote upon and undertake relocation and set-up programs as required for specific exhibitions and hangs.

- Wall Modules are freestanding and can be mechanically fixed to each other to make longer runs of straight or shaped configurations: L, T, H, Z, etc.. Shaped configurations will usually self-support and therefore require less or no ballast or fixing. Longer runs of straight walls may need ballast or fixing as advised in an engineer's specification, depending on the footprint and any project specific certification requirements.
- Wall modules are supplied with heavy duty levelling feet, and the facility for ballast as standard.
- The clear internal cavity of the wall module can be used as storage and be used for mounting showcases, AV equipment, lighting, etc. The rebate channels running along the length of the Cross Rail extrusion can be used to mount a set of common or custom-made brackets and plates (a simple slot-together / bolt-on process) supplied by Designcase, to further increase the versatility of the wall structure. Internal brackets and plates which engage to the superstructure can be used to mount artwork or heavy objects.
- Assembly and demount of the Wall Modules is a simple process requiring basic hand tools and reasonably-skilled staff, physically able to lift the face panels (which will usually be the heaviest individual component) if not being lifted using materials handling equipment. Higher wall modules will require an increase in staffing numbers, mechanical plant and/or lifting equipment during assembly and demount. Basic, freestanding wall structures can be assembled with 2 staff minimum, 3 is our recommendation.
- The standard supply of Face Panels, allows for a small expressed V-groove between panels; this is a standard arris detail applied to all edges for handling and detail purposes. Sharpe, square edges are vulnerable to damage and very hard to align.
- Face panels can be hung, stopped and gap-filled if/as required for a specific display requirement. Short life-span hangs, which require the wall modules to be erected and demounted numerous times over a short period, are better executed by repainting face panels only and accepting the small expressed V-join between face panels. For long-term installations, it is a more viable option to patch and fill the expressed join between face panels.
- Our T2 wall system is 100% fabricated in Canberra using Designcase exclusive profiles and extrusion. We offer the facility to supply a range of project specific additions such as mounting armatures, additional structural rails, Plinths or kickers, replacement parts (such as face panels), and a high level of customisation as a project demands.

Pricing is generally based on the standard height of 2.4m, 3m or 3.6m walls. There is no significant cost implication should you require a custom wall height. We would be happy to discuss this further with you. Customised Widths are available upon request (eg. 1000, 2000, 3000mm wide Modules), again at no significant cost implication.

## **BCA / AS / Certification and Engineering.**

There are no BCA or Australian Standards which govern the installation of Freestanding Gallery Walls, as such T2 defaults to (as an engineering build guide only) the high-specification *Uniform Building Code of America for Engineering of Freestanding Walls*. The UBCA is the Code upon which any submission from Designcase is based. The proprietary/standard T2 wall system already achieves a higher performance rating than required to meet AS1170.4 or similar AS standards (for example), without requiring any additional engineering.

Achieving any given Code is not always a specific project requirement given that T2 is a freestanding wall structure only; is not part of building fabric or base-build, and can be classed as joinery or furniture and fixtures.

Our engineering partners, Coot Consulting Engineers (CCE), have been involved in the development and performance specification of the T2 Wall System. CCE have the correct certification and registration to sign-off on projects across a number of different States and Territories in Australia, noting they default to the UBCA.

Designcase and CCE have developed a document, supplied with live projects, which details the engineering build performance of the proprietary T2 Wall, and includes a guide to ballast loads or ceiling fixing requirements for freestanding walls. However, based on our experience, an exhibition-specific engineering recommendation may be required, based on a specific exhibition floor-plan. The following installation-specific scenario will reduce or negate the requirement for ballast or fixing, but needs to be reviewed on a project-by-project basis, with exhibition plans to hand:

- T2 walls that engage with/are fixed to permanent walls, eg. Perimeter walls.
- T2 walls that are configured into a self-supporting shape, such as L, T, U, Z.
- Low height or wide footprint T2 walls.

Typically, a client appointed project engineer or certifier should review the CCE Engineering Guide in conjunction with the Exhibition Floorplans to arrive at an Exhibition Specific ballast and/or ceiling fixing requirement, in order for the appointed project engineers or certifier to sign-off on the installation – if required as part of the overall project delivery. It is the responsibility of client appointed project engineers or certifiers to offer alternative performance specifications if required to achieve an alternative / nominated certification for this project, prior to fabrication starting. This can be a lengthy process and should be addressed at the earliest opportunity. Exhibition / Project specific certification is not supplied as standard by Designcase and CCE, and generally not included in our submissions. This service is available at a cost variation, and is based on the UBCA. The UBCA is generally regarded as the most high-demand Code for this type of freestanding wall product.





Segmented / faceted T2 Wall. Orientation Wall, as part of the National Museum of Australia *Connection* Exhibition, 2022.



20 liner meters of proprietary T2 walls, consisting 3m and 2m wide 'modules' linked with custom-made 30degree wedge-shape junctions. See images below.



Images courtesy of HOTA – Home Of The Arts.  
HOTA Collects – Gallery 2, 3 and 4



Segmented / faceted T2 Wall.  
Designcase Generic Image





Designcase Generic Image

Above and previous page image illustrating the standard format Designcase T2 wall structure. A nominal shadow-line detail at FFL will account for any uneven floor surfaces, especially important when considering long wall runs or larger shaped configurations.

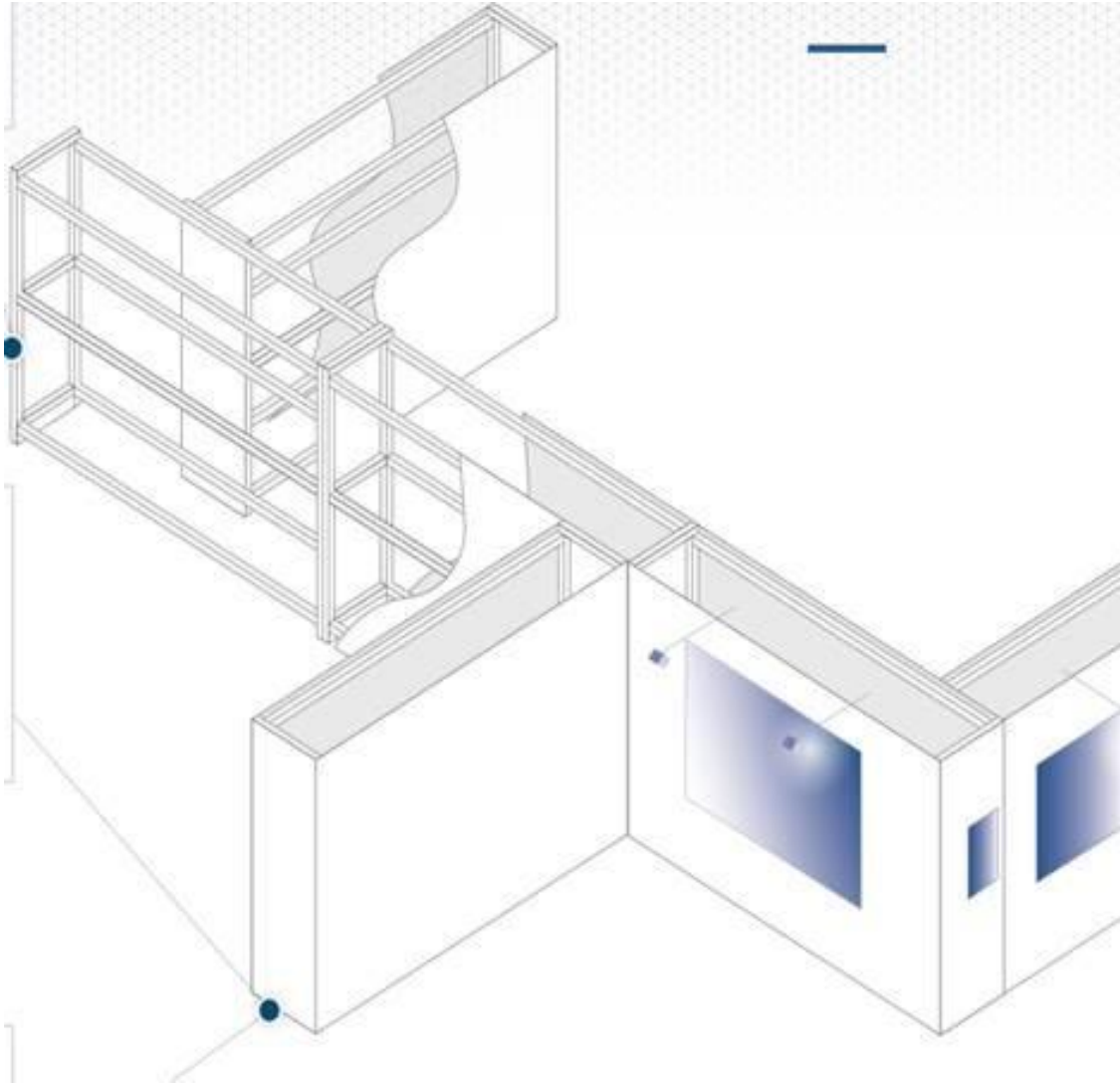

Indicative sketch only, illustrating internal aluminium framing, joinery face panels, and possible build configurations.

Wall Modules are freestanding and can be linked or mechanically fixed to each other, to make long runs of straight or shaped configurations: L, T, H, Z, etc.. Shaped configurations will usually self-support and therefore require less ballast or fixing. Freestanding wall modules do not mechanically engage to floor and ceiling slabs/tracks; they are 100% freestanding. We do have an option for floor and ceiling fixing if/as required.

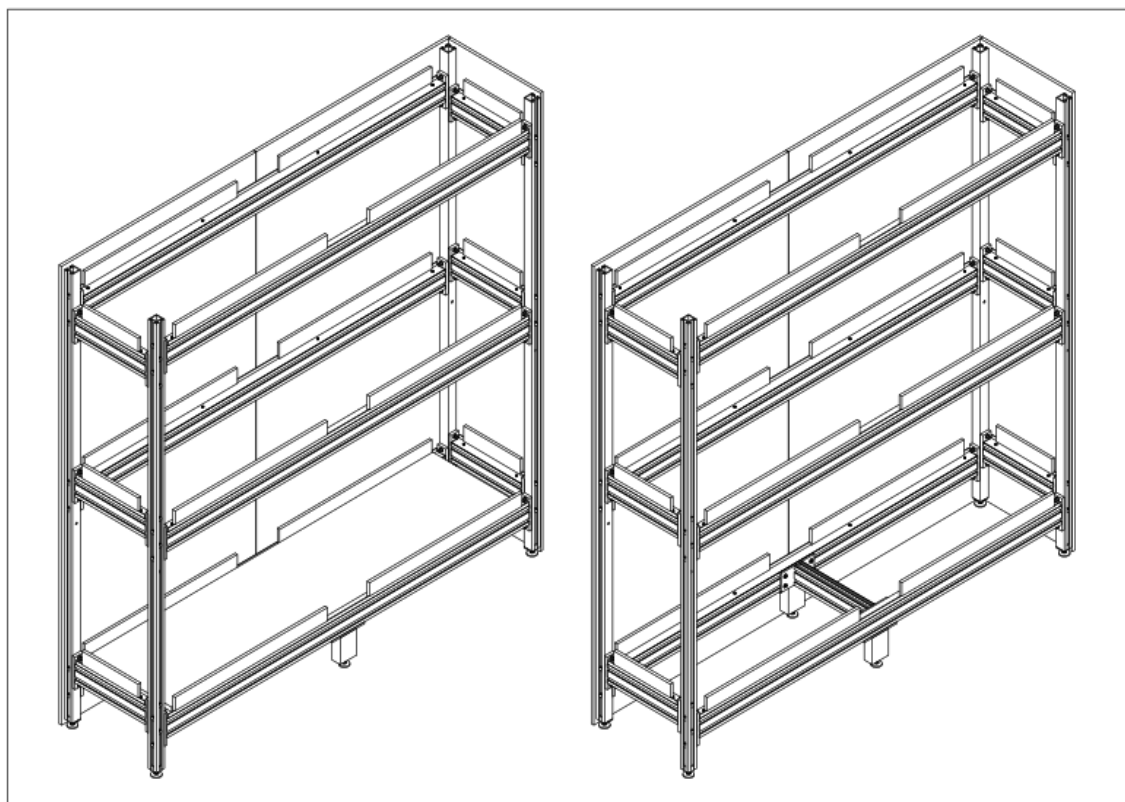
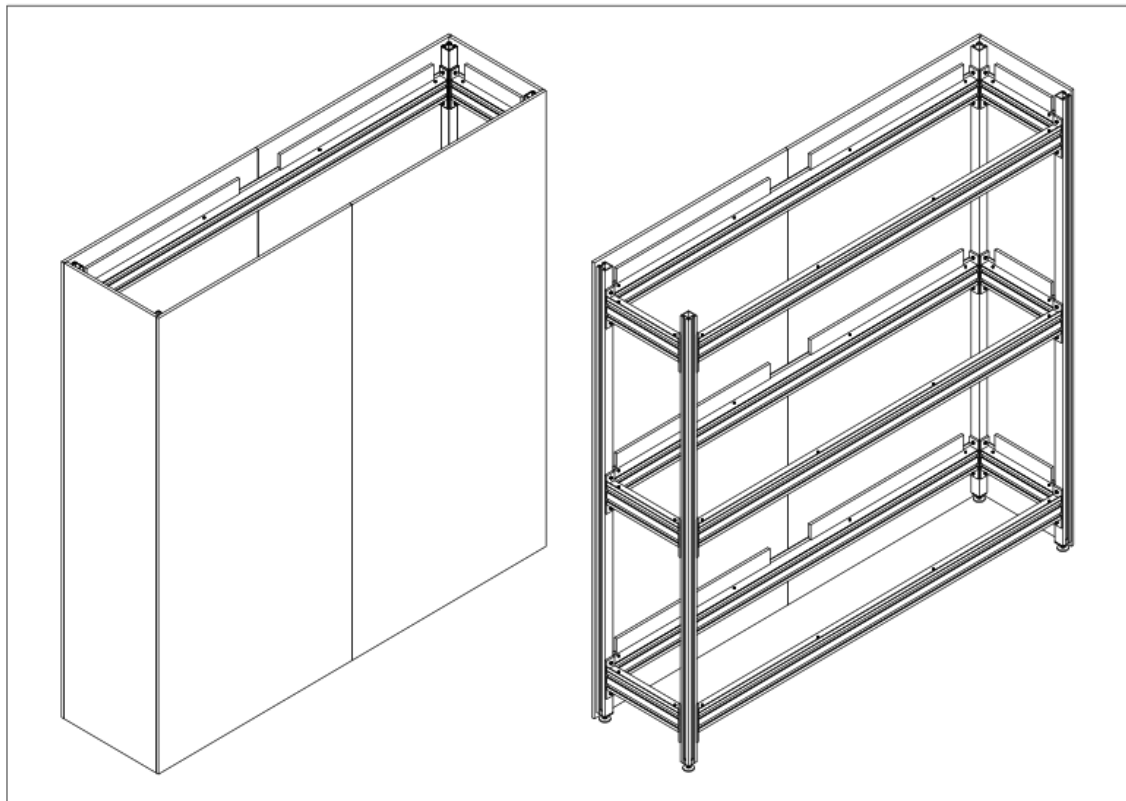

Typical elevations of sheeted and partly un-sheeted Designcase T2 Wall structure. Indicative illustration only, not to scale. The bottom illustration shows the facility for ballast and a solid base panel, supplied as standard.



Typical image of un-sheeted Designcase T2 Wall structure, during an exhibition build. Linked modules shown above: 3600 – 2400 – 3600 frames. The un-sheeted frame structure has been levelled, linked and the Base Panels inserted prior to ballast being inserted and final sheeting.



# designcase



Complex T2 Wall structures are assembled and built in exactly the same way as simple stand-alone walls, or straight runs of linked walls.

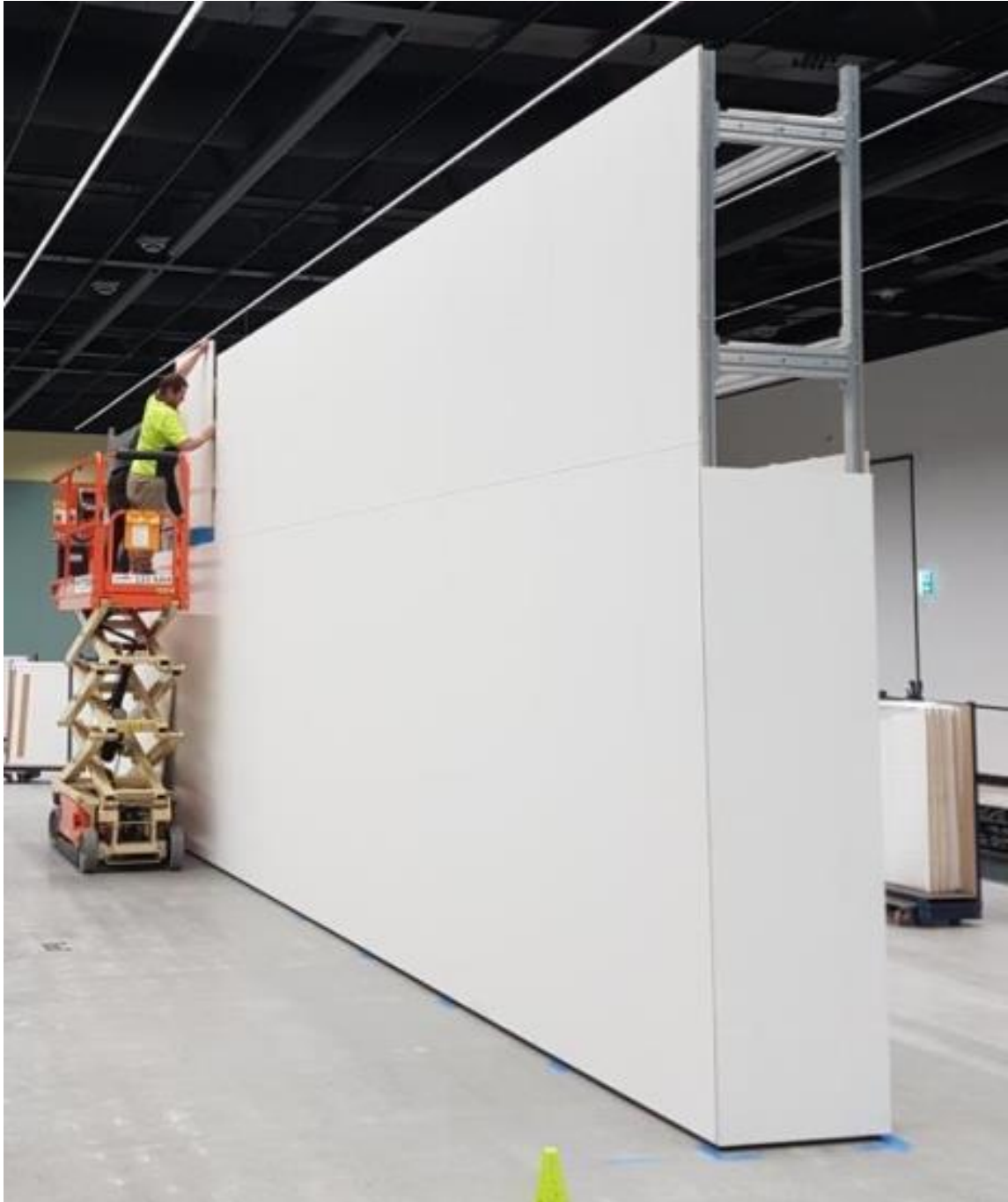

Typical image of larger format Designcase T2 Wall structure being sheathed, during and exhibition build. Linked modules shown above: 3600 – 3600 – 1200 – 3600mm frames, at 4.2m high. Very high wall modules will require the Face Panels to be supplied in 2 parts / have split-level face panels. The use of a face panel material such as Lite Ply reduced the overall weight of the Module, but also reduces the weight of the top panel / upper level panels.

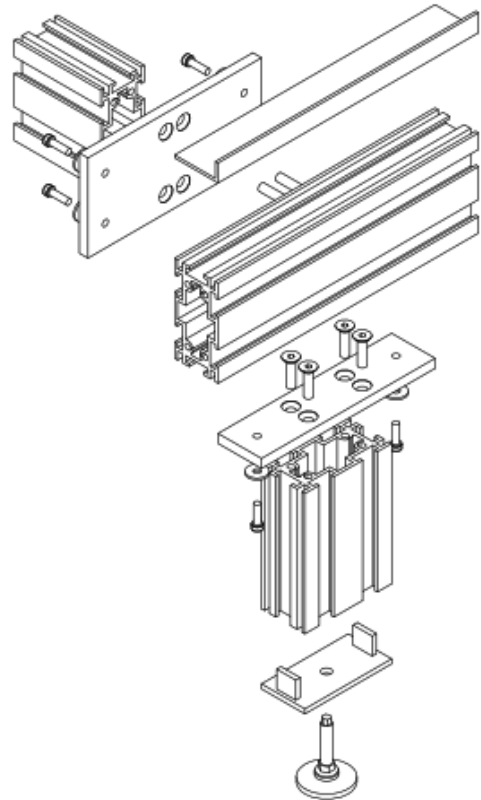
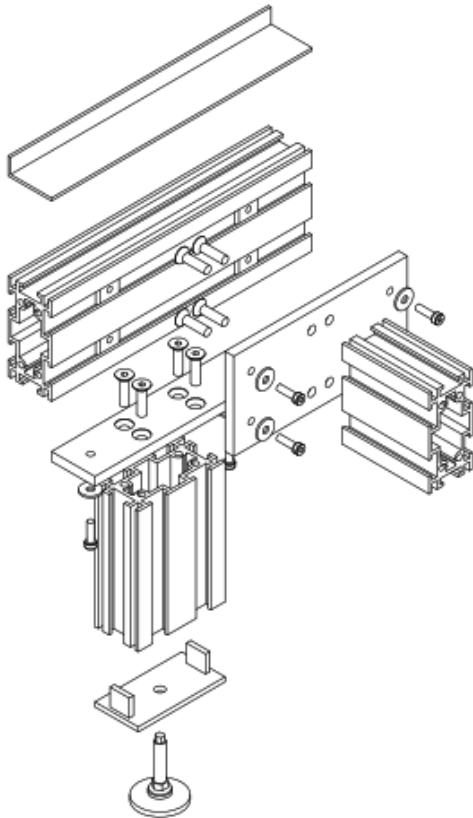
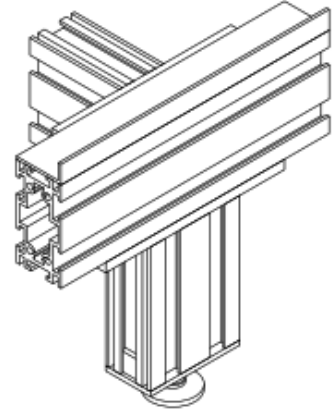
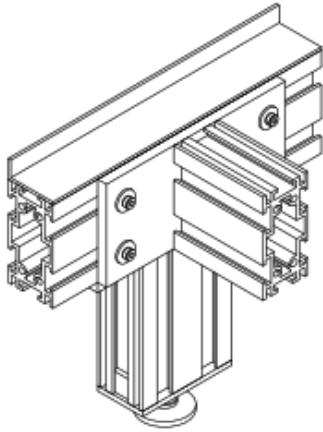

Typical engineering and assembly elevations.

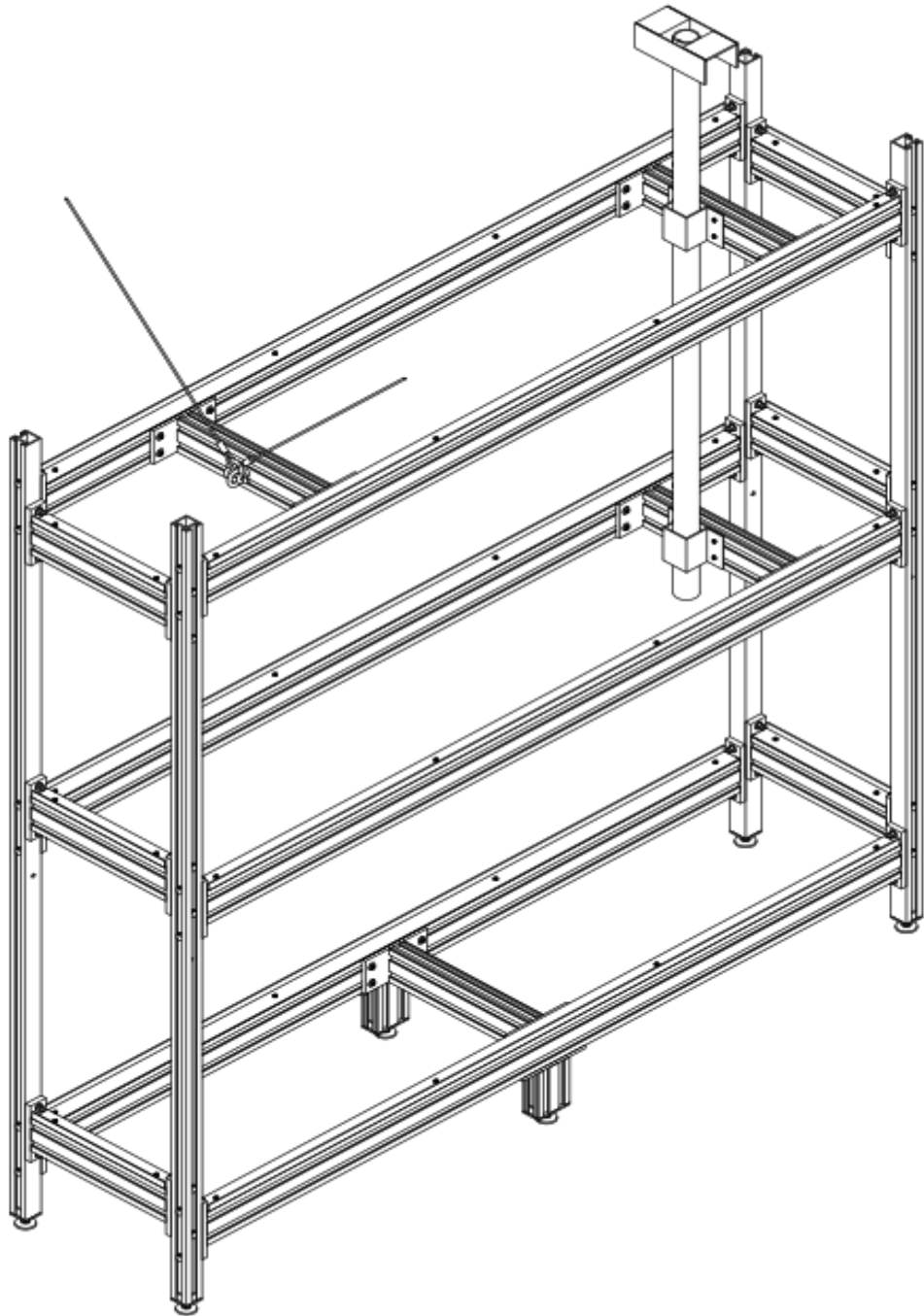

Generic elevation of un-sheeted Designcase T2 Wall structure, detailing the options for Ceiling-slab fixings. Pairs of tensioned wire cables engage with anchor points in the ceiling slab, to triangulate the wall-to-ceiling junction. Stabilising Poles are removable and can be positioned anywhere within the aluminium frame structure, to avoid ceiling services such as HVAC and Fire services. Both options usually negate or significantly reduce the required ballast loading. Indicative illustration only, not to scale.